

# WATCH SIZE GUIDE

Use this chart to see which watch sizes fit you best. Just print at 100%, cut out the sizes you're considering, and hold up to your wrist to find the perfect fit.

## PRINT INSTRUCTIONS

1. Open this PDF in Adobe Acrobat Reader
2. Select Print and check Print Settings
3. Select "actual size" or "turn off scaling" or "set scaling to 100%" depending on your options.
4. This will ensure your chart prints with accurate sizing.

For complete accuracy, the line below should measure exactly.

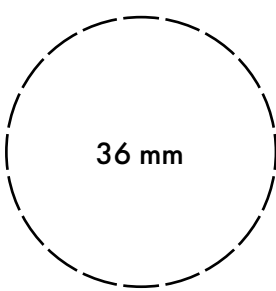
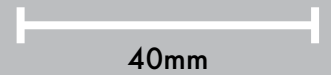

36 mm

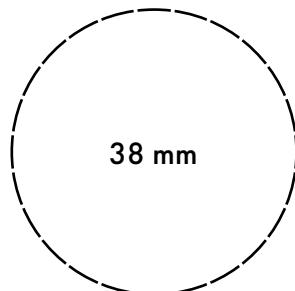

38 mm

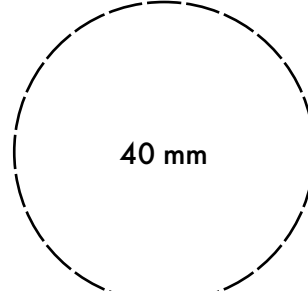

40 mm

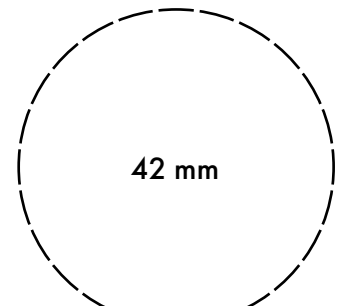

42 mm

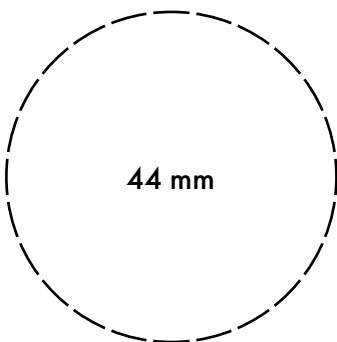

44 mm

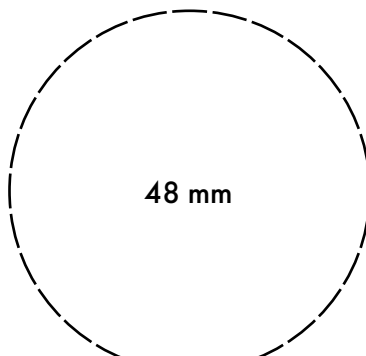

48 mm

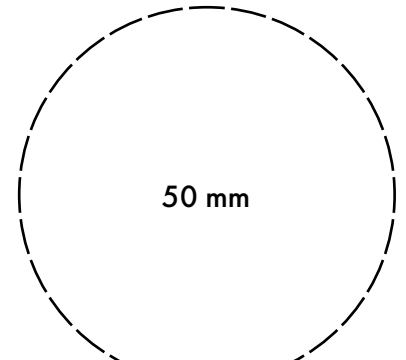

50 mm

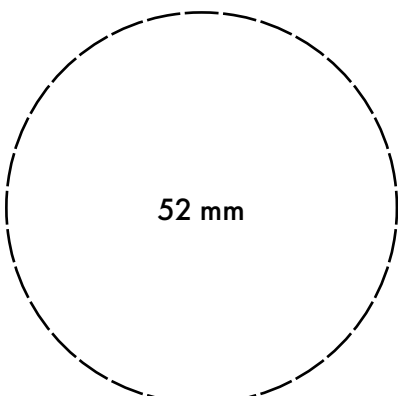

52 mm

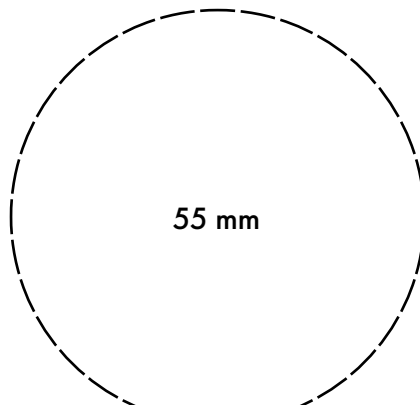

55 mm

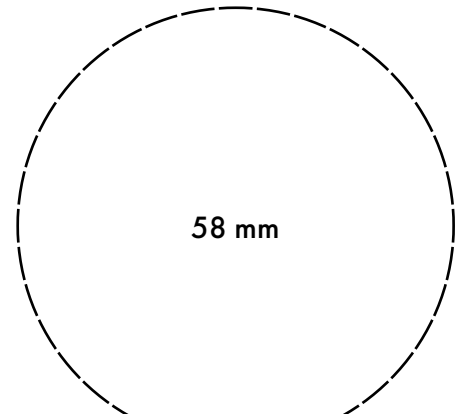

58 mm